

## 1. Write down various energy conservation measures adopted in Railways?

1. Energy audit to be conducted to monitor and minimize energy consumption per unit output.
2. Use capacitors to improve power factor to reduce maximum demand charges based on kVA, reduce losses and improve voltage.
3. Control leakages of water, gas, air, electricity etc.
4. Lubricate motors, pumps etc.,
5. Control idle running of machines. Switch off equipments like feeders transformers, welding sets etc. from mains to control no load losses
6. Use alternate source of energy
7. Display energy conservation measures
8. Review existing installations for latest designs locations and do energy audit
9. Control maximum demand by staggering loads; cutting of loads when MD is exceeded, provide alarms for indicating MD exceeding limits.
10. Select motor drive keeping in view the requirement of load. The efficiency of a drive is high at full load. Replace oversized motors, as efficiency will be low at low loads.
11. Select high efficiency motors. Replace energy inefficient motors when they are due for rewinding.
12. Select efficient speed control system in the drive. Resistance control wastes energy.

### Ovens

13. Electrical heating is expensive. Select oven of optimum oven size.
14. Use ovens on full load. Stop idle running of ovens.
15. Ensure efficient temp. control. Thermostats should be in working order.
16. Plug all leakages. Do not open door unnecessarily.

### Lights and fans.

17. Natural lighting and ventilation should be used to the maximum extent. North lights and FRP translucent sheets should be used in roof area of sheds, shops etc.
18. Low height partitions should be used.
19. Suitable light finish of interior surfaces and furnishings should be maintained for maximum utilisation of inter-reflection of light. Task lighting should be provided.
20. Minimum possible heights for mounting tube lights etc. should be selected.
21. Replace incandescent with efficient luminaries such as CFL
22. Use electronic fan regulators
23. Use tuners, door switches, group control switches, photo control switches to switch off lights/fans/water coolers etc.
24. Luminaries should be cleaned periodically
25. Avoid indirect/fancy/decorative lighting/
26. Use voltage controls to dim lights.

### Pumps

27. Throttling of pumps is wastage of energy. Sometimes speed of drive can be controlled to reduce flow. Use of pumps in series parallel to meet the requirement at various hours of the day can be effective
28. Use broader opening foot valve and avoid high resistance foot valve
29. Replace elbows with 90o long radius bends and undersize suction pipes.
30. Reduce unnecessary height of delivery pipes
31. Periodical maintenance is necessary.
32. Avoid overflow in storage tanks and leakage of water through joints, valves and taps.
33. Replace over size pumps.
34. Do maximum pumping at night to save on MD.

### Refrigeration and air conditioning

35. Select highest temperature required for desired quality in refrigeration/air conditioning system.
36. Use false ceiling and partitioning to enable reduction of volume for air condition/refrigeration.
37. Use of auto door closer, air curtain and vinyl curtain are useful to minimize the heat ingresses from outside. Use of double glass windows and double doors in AC area. Use efficient lighting and electronic chokes and fan regulators in AC areas.
38. Switch off AC an hour prior to office closing and switch off water coolers during the night. Plan timing and use timers.
39. Periodical maintenance necessary.

### Compressed air system

40. Compressed air system converts 5% energy to useful energy. Hence use of compressed air should be minimized. Cleaning by compressed air is rarely justified.
41. Select capacity and pressure. 10% reduction in pressure can save 5% energy.
42. Stop leakage of air and reduce length of air pipeline.
43. Use of high efficiency drive with automatic speed control can save energy.

### Transformer and distribution

44. Use high efficiency transformers.
45. Switch off the standby transformer to control no load losses. Changeover can be done periodically to avoid drop in IR. Switching of the transformer on holidays is also useful running the transformer on full load also helps.
46. Use high voltage for longer distribution line.
47. Improve power factor. Improving the power factor from 0.7 to 0.92 can save 42% peak line losses and 24% reduction in peak demand.
48. Switch off feeders when not required during the day.
49. Do regular maintenance of transformers and distribution lines.

## 2. What is power factor? What are the effects of PF? How to improve PF? Power factor calculation?

**Power factor :** It is the ratio of true power to apparent power

$$\text{PF} = \frac{\text{True power}}{\text{Apparent power}} = \frac{\text{KW}}{\text{KVA}} = \frac{\text{Watts}}{\text{Voltage amp.}}$$

$$= \frac{\sqrt{3} EI \cos \phi}{\sqrt{3} EI}$$

### **Disadvantage of low power factor.**

1. Cost of generating station is high for a given power requirement at load in case of low power factor at load.
2. Size of conductor will be high..
3. Voltage regulation will be poor.
4. System losses will be high.
5. Energy bill will be high for given load at low PF

### **Causes for low power factor.**

1. Inductive load in the system.
2. Operation of motor at lower load.

### **Methods for improving power factor**

1. Phase advancer – special designed induction motor which will work nearer to unity power factor.
2. Synchronous Induction Motor – Specially designed to operate with over excited fields so that it will draw leading current.
3. Static condensers.

### **Formulae for finding out KVAR requirement**

To improve the power factor from  $\cos \phi_1$  to  $\cos \phi_2$ , the KVAR rating of capacitor is  $P(\tan \phi_1 - \tan \phi_2)$  where P is the load in KW.

Problem: In a factory the load is 480 KW at power factor 0.75 power factor.  
Find out KVAR capacity required to improve to PF from 0.75 to 0.95?

Solution :

$$P = 480 \text{ KW}$$

$$\cos \phi_1 = 0.75$$

$$\cos \phi_2 = 0.95$$

$$\phi_1 = \cos^{-1}(0.75) = 41^\circ 24' \quad \tan \phi_1 = 0.8816$$

$$\phi_2 = \cos^{-1}(0.95) = 18^\circ 12' \quad \tan \phi_2 = 0.3288$$

Therefore KVAR rating =  $P(\tan \phi_1 - \tan \phi_2)$

$$\begin{aligned} &= 480 (0.8816 - 0.3288) \\ &= 265.344 \text{ KVAR} \quad (\underline{\text{ANS}}) \end{aligned}$$

### **3. What are the various types of pumps used in Railways?**

#### **CENTRIFUGAL PUMPS:**

These pumps employ Centrifugal force to lift liquids from a lower level to higher level. These pumps comprises an impeller rotating on a volute casing. Liquid led into the centre of impeller is picked by the vanes and accelerated to high velocity by rotation of the impeller and discharged by centrifugal force at the periphery. When a liquid is forced away from the center, a vacuum is created and more liquids flows in, consequently there is a constant flow through the pumps.

There are two types of pumps.

##### **i. SINGLE STAGE PUMP:**

Centrifugal pumps with single closed type impeller with single suction is called single stage pumps. These type of pumps used generally when the head is less than 60 ft.

##### **ii. MULTI STAGE PUMP:**

These pumps may have two or more impellers operating in series. I.e. the discharge of one impeller is connected to suction of other.

#### **VERTICAL TURBINE PUMP**

These pumps are designed for vertical operation and find their application in various fields where centrifugal pumps cannot be used either due to their limited suction capacity or due to medium capacity demands.

These type of pumps motor is erected above the ground level and having extended shaft upto the pump.

The shaft is coaxially connected in column pipe, which serves dual purpose of water delivery and supporting base for stationary parts of the pump.

These pumps particularly suitable for installation in open wells or medium bore wells. These are the best pumps for pumping water to cities and towns from river or deep wells.

#### **SUBMERSIBLE MOTOR PUMP:**

These pumps are, both motor and pump are installed, deep inside the tube well, so that suction lift is minimised which make it possible to lift the water from depths as low as 450 metres.

These pumps are essentially single or multistage centrifugal turbine pumps designed to form a compact unit in conjunction with a coupled wet type squirrel cage induction motor both of which operate totally submersible below the surface of water.

Submersible pumps with radial flow impeller are made for low discharge with high total heads, whereas pump with mixed flow type impellers are made of medium discharge with medium heads.

## **EJECTO (JET) PUMP:**

Ejecto pump is based on the principle of conversion of hydraulic energy from one form to another form.

When high pressure water is passed through a converging passage, the pressure head is converted into velocity head, similarly when water having high velocity head is passed through a diverging passage, it gets converted into pressure head.

The principles of Ejecto pump can be summed up as –

- i) Creating partial vacuum and lifting water from the well
- ii) Imparting sufficient pressure energy to water, so that it is raised from the depth to the desired levels.

## **ADVANTAGES OF EJECT PUMPS**

### **i) OFF SET INSTALLATION.**

This is a unique feature of Ejecto Pump. It can be installed away from the source of water upto a distance of 90m or even more.

### **ii) EASY TO MAINTAIN**

As the pump can be installed at convenient place away the well source, maintenance becomes very easy to accessibility.

## **AIR LIFT PUMPS.**

In this pump water is lifted by making use of compressed air which is led to the bottom of the rising main and injected into the water in an upward direction very similar to the water jet.

The pumping action is based on the fact that if air is admitted in the form of small bubbles into the bottom of a column of water in sufficient quantity to aerate the water, the specific gravity of the water in the pipe is automatically reduced depending upon the air to water ratio. Therefore the water level in the pipe rises upto a height above the water level in the well, determined by the amount of air admitted. This type of pump is particularly well adopted for pumping water from the deep boreholes of 50 ft. to 500 ft. depth.

1. Calculate the HP of the motor of a pump with discharge of 50,000 litres per hour at 100M head.

**Solution:-**

$$\begin{aligned} \text{Given, discharge} &= 50,000 \text{ LPH} \\ &= 50,000/3600 \text{ LPS} \\ \text{Head} &= 100 \text{ M} \\ \text{WHP} &= \frac{\text{Discharge in LPS} \times \text{Head in Metre}}{75} \\ &= \frac{50,000 \times 100}{3600 \times 75} \\ &= 18.5 \text{ HP} \\ \text{IHP} &= \frac{\text{WHP}}{\text{Pump efficiency} \times \text{Motor efficiency}} \\ &= 18.5 / 0.5 \\ &= 37 \text{ HP} \end{aligned}$$

(Assumption : Combined motor and pump efficiency of 50%)

Ans: HP of the motor of a pump = 37 HP.

#### 4. What is the principle of a transformer? Factor to be considered for paralleling of transformer?

- Transformer is a static machine which increases or decreases the ac voltage without changing the frequency of the supply.
- The principle of working of a transformer is based on the mutual electromagnetic induction.
- Transformer generally consists of two windings called primary and secondary. These coils are electrically isolated but magnetically linked through the core, which offers less reluctance to the magnetic path. Thus when supply is fed to one coil, magnetic flux will be produced, most of which will link with the other coil thus the energy is transferred from one coil to other. Based on the number of turns in the coils, the voltage fed is increased or decreased.

#### CONDITION FOR PARALLELING OF TRANSFORMER

- Polarity of the two transformers must be same
- Two transformers must have same voltage ratio
- Both the transformers must have same percentage impedance
- In poly phase, phase rotation must be same and the transformers must have same phase displacement or vector grouping.

5. Draw the layout of 11KV/440V outdoor substation?

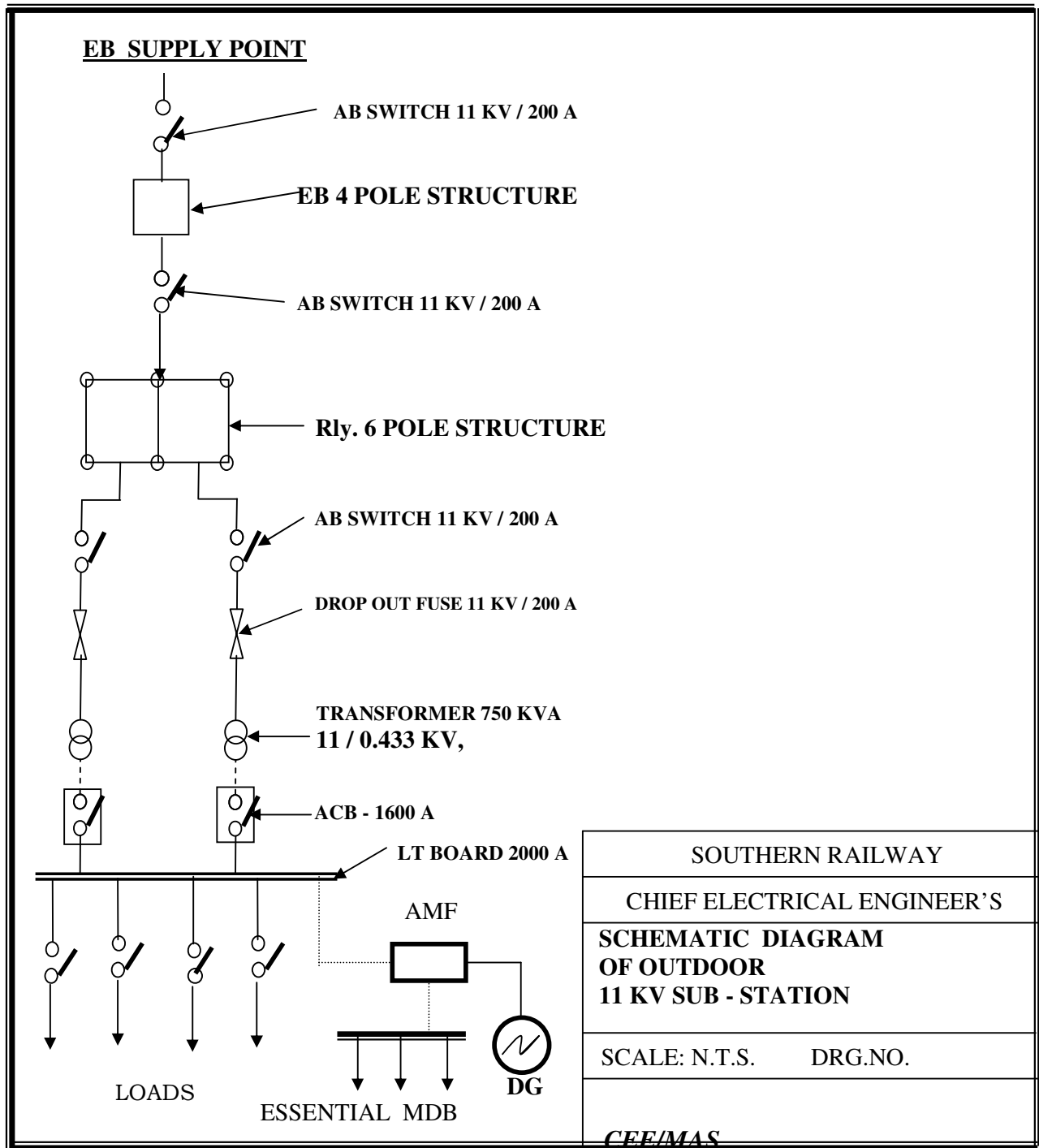



## 6. What is the need for earthing? How to lay a pipe earth? How to test earth?

1. Write down the procedure of testing an earth with an earth megger.

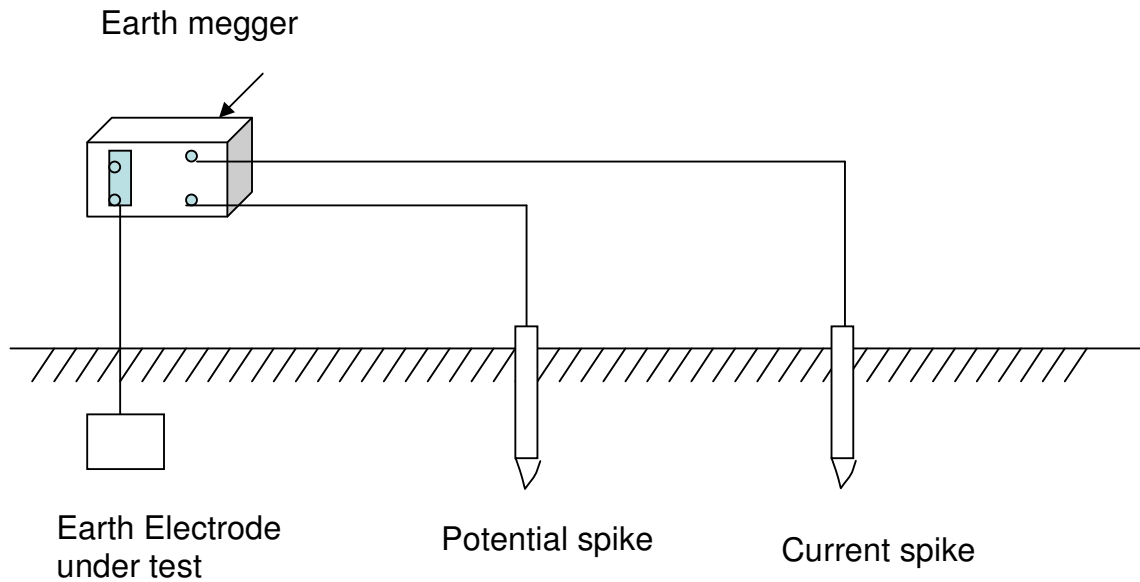

The resistance of the earth electrode can be measured by using an earth megger. The C1 & P1 of the earth megger is shorted and connected to the earth electrode under test. A potential spike is driven in to the ground at 75 feet from the earth electrode under test and connected to P2 of the megger. A current spike is driven in to the ground at 150 feet from the earth electrode under test and connected to C2 of the megger. By rotating the megger, the earth resistance value can be directly read from the scale of the megger.

7. What are the various terms used in illumination? What are the qualities of good illumination? What are the various types of lamps used its lumens & life?

#### Radiation

Emission or transfer of energy in the form of electromagnetic waves is known as radiation.

#### Light

Any radiation, which is capable of causing a visual sensation on the eye directly, is termed as light. The band of wavelength that corresponds to visible light lies between 380 nm and 780 nm ( $1\text{nm}=10^{-9}\text{ m}$ )

#### Visual spectrum

In the spectrum there are various band of wavelength, which causes a visual sensation and produces colour effect these color bands are:

380 nm – 435 nm:	violet
435 nm – 500 nm:	blue
500 nm – 566 nm:	green
566 nm – 600 nm:	yellow
600 nm – 630 nm:	orange
630 nm – 760 nm:	red

#### Luminous flux ( $\Phi$ )

It is the quantity of radiant flux (light) emitted by a lamp. And is measured in lumen. As per definition lumen is equal to the radiation emitted by a point source per solid angle.

#### Coefficient of Utilisation (C.O.U.)

It is the ratio of the lumens reaching the working plane to the total lumens produced. It is also called “Utilisation Factor”. C.O.U. depends on, light distribution of the luminaire; light output ratio of the luminaire; reflectance of the ceiling, walls and working plane; room index and arrangement of the luminaire in the room. C.O.U. is based on new, clean equipment and in practice a maintenance factor is introduced to convert from initial to in-service illumination.

#### Reflection factor

It is the ratio of the reflected light to the incident light.

#### Luminous efficacy ( $\eta$ )

Quantity of light (lumen) emitted for each unit of electrical power (watt) consumed. The unit is ‘lumen/watt’ (lm/W).

#### Glare

It is one of the negative factors of any illumination design. A commodity that leads to a condition in which there is discomfort or a reduction in the ability to see objects, or both, due to an unsuitable distribution of intensities/extreme contrasts in the field of vision.

Space height ratio

It is the ratio of horizontal distance between adjacent lamps and mounting height of the lamps. The manufacturer indicates it for given luminaire

Uniformity ratio (UR)

This ratio gives idea about the uniformity of lux level obtained from design, It is the ratio of the minimum lux to the average lux. For more intense uniformity ratio of minimum to maximum lux can be taken.

**Advantages of Better Illumination**

Clear visual perception of object and surrounding.

Increased efficiency and better appearance

Better utilization of time by not depending on direct sun light.

Reduction of eyestrain and better health of community

High reliability and continuity.

## 8. Write down power shutdown procedure?

(A) person need shut down has to give requisition on the proforma EE 243 asking for power shutdown in particular circuit.

(B) ) Authorized person will give permit to work proforma EE 244 after switching off the power supply.

(C) On completion of work authorized persons has to give proforma EE 245 saying that all works completed and all persons and tools are removed from the equipment and equipment can be re energized.

(D) Whenever more than one group is working on the same distribution circuit a senior most person should be incharge for both the group.

(E) Whenever more than one group is working the earthing of equipment shall be done either side of the section

(F) Before commencement of work on any electrical equipment after taking shutdown. Following works are to be done.

(i) Identify the electrical equipment.

(ii) Switch Off

(iii) Isolate

(iv) Discharge.

(v) Earth it.

(vi) Provide caution / danger notice on particular equipment ie. men working

(vii) The person who is possessing competency certificate only to be allowed to undertake any work on Electrical equipments.

### (G) Self Shut Down

Where an Electrical Department official himself has to work on an individual item of electric equipment, which is directly under his control, such as on a motor or crane supply lines in a workshop, it is not necessary to use forms prescribed in the above procedure but in all such cases an authorized person will be continuously present at site when work is in progress. The prescribed forms will however be required if any of his staff belonging to other departments are required to work on or near the wires.

## 9. Write about IE rules.

- IE Rules are framed by Central Electricity Board in exercise of the powers conferred by section 37 of the Indian Electricity Act 1920.
- These rules have got statutory effect.
- Chief Electrical Engineer/MAS is the Electrical Inspector to Government (EIG) for Southern Railway.
- EI can appoint officers to assist him.

### **Powers:**

- EI can Examine any place, carriage, vessel where there is generation, power transmission, distribution and utilization.

### **Voltages:**

- Low voltage: Not exceeding 250 volts
- Medium voltage: not exceeding 650 Volts
- High voltage: does not exceed 33,000 volts
- Extra high voltage: exceeding 33,000 volts

### **Permissible variation (rule 54)**

cannot be

- More than 6% in the case of low and medium voltage
- More than 6% on higher side and 9% on lower side in the case of high voltages
- More than 10% on higher side and 12.5% on lower side in case of extra high voltages

### **Frequency**

- Should not permit the frequency of the alternating current supply vary from declared frequency by more than 3%  
ie., 48.5 to 51.5 Hz.

### **Responsibility of the supplier**

- Ensure the lines, wires, fittings, installed in the consumer premises are in good working condition, adequately designed
- Cutout on consumer premises (other than neutral conductor) in an access and enclosed in fire receptacles.
- Earthing in an easy access position

### **Responsibility of consumer**

- Take precaution for safe custody of the equipment.

### **Accessibility of the bare conductor**

- Ensure they are not accessible
- Provide switch in readily accessible position
- Take such precaution as considered necessary by the EI

### **Provisions applicable to protective equipments:**

#### **Danger notice:**

- MV/HV/EHV installations should affix permanently in a conspicuous position a Danger Notice in Hindi or English and Local Language (motor, generator, transformer, structures, supports with HV/EHV etc)
- If it is not possible to affix such notice on any generator or motor etc., they shall be fixed as near as possible.
- when many of them are kept in a single enclosure one notice affixed to the enclosure should be sufficient.  
{Exception: Traction Masts in Railways}
- No person shall work on live electrical supply lines unless he is authorized in that behalf and takes safety measures as authorized by EI.
- All persons working on supply lines should be provided with tools and devices such as gloves, rubber shoes, safety belts, ladders, earthing devices, helmets, live testers etc., to protect from mechanical/electrical injury.  
(Such tools should be maintained in efficient working condition)

#### **Fire fighting:**

- All switching stations should be provided with fire bucket filled with clean dry sand for ready use
- Fire extinguishers like CO<sub>2</sub> , DCP etc., should be kept in conspicuous places.
- Staff should be trained for emergency operation.
- Tested for satisfactory operation once in a year and records maintained for such tests.
- First aid box should be provided in all gen. Station, substation etc.,
- Instructions in tri languages for shock treatment should be made available.
- Authorized person and competency certificate

#### **Periodical inspection:**

- Every installation which is already connected to the supply system shall be periodically inspected and tested at intervals not exceeding 5 years by EI

#### **Electrical accident:**

- If any electrical accident occurs and resulted in loss of human or animal life or any injury to any human/animal the authorised person not below the rank of Junior Engineer should sent the telegraphic report to EI with in 24 hours of the knowledge of the occurrence of the fatal accident. A detail report should follow with in 48 hours in the prescribed format.
- The EI on receipt of the intimation may arrange for inquiry as considered necessary and fix up the responsibility of the staff and take action against the concerned if anyone is found directly responsible

**Minimum breaking strength for the conductors:**

- For LV lines 150 Kgs.
- For all others 350 Kgs.
  
- Joints: the ultimate strength of the joint should not be less than 95%
- Max span : 65 M

**Vertical Clearances:**

- Across the street:
  - LV and MV : 5.8 M
  - HV : 6.1 M
  - EHV : 6.1 M
- Along the street:
  - LV and MV : 5.5 M
  - HV : 5.8 M
  - EHV : 6.1 M

Elsewhere:

- LV and MV : 4.6 M (bare conductor)
- HV : 4.0 M (insulated conductor)
- HV above 11 KV : 5.2 M
- EHV : 5.2 + 0.3 M for every 33,000 volts thereafter

**Clearance from buildings**

For LV & MV:

- Vertical: 2.5 M (minimum)
- Horizontal: 1.2 M
- If adequate clearance is not available the conductor should be insulated

For HV and EHV lines:

Vertical:

- Upto 33 KV : 3.7 M
- For EHV lines : 3.7 + 0.3 M for every addl. 33 KV and thereafter.

Horizontal:

- Upto 11 KV : 1.2 M
- 11-33 KV : 2.0 M
- For EHV : 2 + 0.3 M for every addl. 33 KV or part thereafter.

**Rule 51.**

Every MV/HV/EHV switch board shall comply the following:

- A clear space of not less than one metre in width in front of the switch board
- The space behind the switch board shall be less than 20 cm or more than 75 cm.
- If the space behind the switch board exceeds 75 cm, there shall be a passage-way from either end of the switch board clear to ht. of 1.8 mts.

**Rule 57 (meters)**

- Meters should be adequate capacity
- The error should not exceed 3% above or below absolute accuracy at all loads and in excess of one tenth of full load and up to full load

- For EHV the error limit is +1%.

**IE rule 61: (connection with earth)**

- Connection with earth is essential where the voltage is normally exceeds 125 volts.
- Neutral conductor shall be earthed by not less than two separate and distinct connection with a minimum of two different connections.
- No cutout, no switchgear, no CB in the earth circuit.
- No earth connection with any water pipe line
- The frame of every generator, stationary motor, portable motor and the metallic parts of the transformers etc., shall be earthed by two separate earth connections.
- All metallic casing, metallic coverings, portable equipments etc., shall be connected with earth
- All earthing system belonging to the supplier shall be tested for resistance on dry day during the dry season not less than once in two years.
- A record of the testing shall be kept after testing and made available to EI
- The supply of energy to every elec. Installation (other than LV below 5 KW) shall be controlled by earth leakage protective device. (exception OH lines)

**Rule 64. Minimum clearance bare/live parts**

Voltage	Ground clearance	Sectional clearance
Not > 11 KV	2.75 M	2.6 M
33 KV	3.7	2.8
66 KV	4	3
132 KV	4.6	3.5

- Transformer more than 2000 ltrs. Of oil shall not be located in basement Baffle wall [ of 4 hours fire rating]
- Provision for soak pit if oil is more than 9000 ltrs.
- Fire protection equipments
- Cable trenches shall be filled with sand covered with non-inflammable slabs.
- Apparatus may be so arranged that they may be made dead in sections.
- EHV apparatus shall be protected against Lightning and switching over voltages Interlocks protection

**IE rule 68**

- Outdoor substation shall be efficiently protected by fencing not less than 1.8 M in height

**IE rule 70**

- Condensers: suitable provision shall be made for immediate and automatic discharge of every static condenser on disconnection of supply.

**Rule 71 (luminous tube installations)**

- Shall be inaccessible for unauthorized person
- Protection against weather, isolated to extent possible
- Secondary shall be earthed and the core of the every transformer shall be earthed
- ELCB on live side
- Separate sub-circuit for each transformer

**Caution notice**

- Static condensers shall be on primary of the transformer with auto discharge in the event of supply cut off.



## 10. What are uses of a starter for a motor? Explain DOL, Star-Delta starter?

Starter is used in the motor to

1. Reduce starting current.
2. To protect the motor from over load.

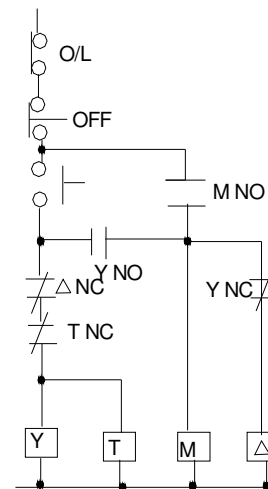
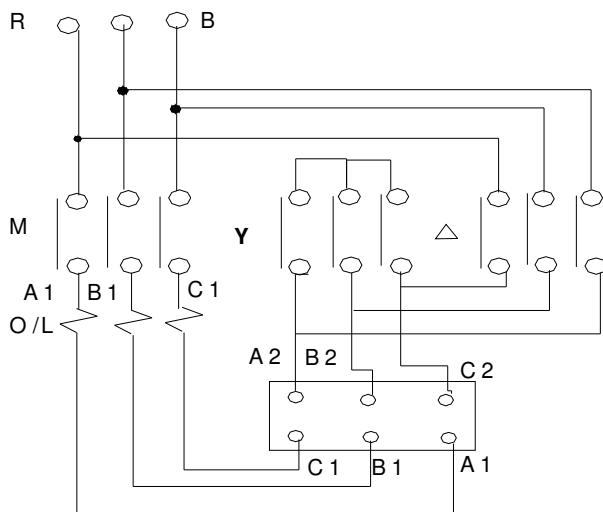
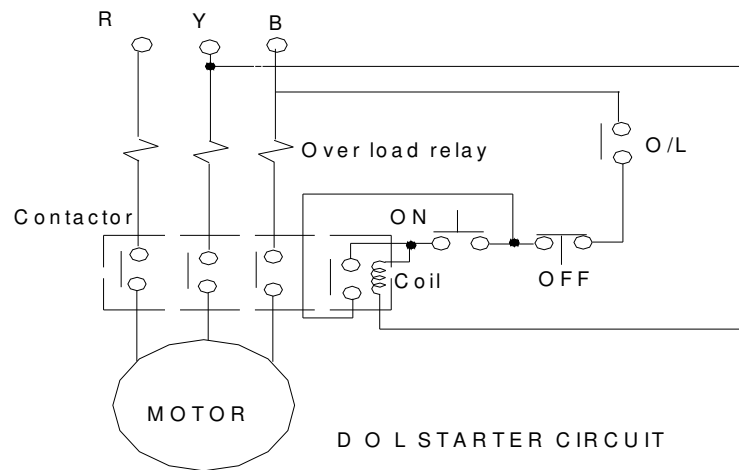

## 11. Write down the scheduled maintenance of Transformer?

<b>s.no</b>	<b>Hourly</b>	<b>Inspection notes</b>	<b>Action</b>
1	Load	Check against rated figure	Reduce the load if higher
2	Temperature	Check oil temperature	Switch off if the oil temperature is high
3	Voltage	Check against rated figure	Take corrective action
<b>s.no</b>	<b>Daily</b>	<b>Inspection notes</b>	<b>Action</b>
1	Dehydrating breather	Check the colour of silica gel	If silica gel is pink change it. If it is in pale blue, then it is in good condition
<b>s.no</b>	<b>Monthly</b>	<b>Inspection notes</b>	<b>Action</b>
1	Oil level in transformer	Examine the oil level and dirt deposits	Clean or replace
<b>s.no</b>	<b>Half yearly</b>	<b>Inspection notes</b>	<b>Action</b>
1	Oil conservation	Check the moisture	Improve ventilation
2	Cable boxes	Inspect for leaks, cracks etc.,	Attend defects if any
<b>s.no</b>	<b>Yearly</b>	<b>Inspection notes</b>	<b>Action</b>
1	Transformer oil	Check the dielectric strength	Take suitable action to restore the quality of oil
2	Earth resistance	Check values of earth resistance	Take suitable action if earth resistance is high
3	Relay alarms and their circuits	Examine relay and alarm contacts, their operation fuses etc. check relay accuracy	Clean the component and replace the contact and fuses
<b>s.no</b>	<b>5 Yearly</b>	<b>Inspection notes</b>	<b>Action</b>
1	Core and winding	Overall inspection including lifting of core and coils	Wash with clean dry oil

These are the schedule maintenance for the transformer of capacities less than 1000 KVA

## 12. Write down the scheduled maintenance of DG set?

### **DAILY SCHEDULE**

#### Engine

- Check previous day's log book and take corrective action as required.
- Before starting the engine, check drain water and sediment from fuel tank and fuel water separator through drain cock.
- Check fuel, oil, water and fill radiator with chromate concentration 3500 ppm treated water and radiator cap must be tightened properly to avoid aeration and over-heating of the coolant.
- Check air cleaner oil level and top up with clean engine oil, if required.
- Check air line connections for leaks and correct if necessary.
- Drain condensed from air receiver tank at beginning of each shift and then closes the drain cock properly.
- Start the engine and note the oil pressure both at idling i.e. 15 psi (1.09 Kg/cm<sup>2</sup>) minimum, and rated speed 5070 psi (3,363 to 5.08 Kg/cm<sup>2</sup>) minimum. In case in change of oil pressure, then stop the engine and check through trouble shooting techniques the cause and correct if necessary.
- Engine oil should be checked at least 20 minutes after stopping the engine and top up if necessary.
- Record oil pressure. Fill fuel tank if required.

#### **Electrical system**

##### **Batteries**

- Clean the batteries with dry cloth.
- Tight the connection if required.

##### **Switch Gear**

- Check automatic starting switch for its proper functioning.
- Check any abnormality if visualized.
- Check phase indications and working of panel meters.

##### **Alternator**

- Check any abnormality, if visualized.
- Check the air-in and out restrictions.

## **WEEKLY SCHEDULE**

In addition to Daily schedule, carry out the following checking;

### **Engine**

- Check the lubrication oil level in engine and governor and top up if necessary.
- Check the coolant oil for its proper functioning.
- Check the constant heater functioning
- Check the anti-freeze and concentration of coolant, if any
- Check the condition of belt for its proper tension.
- Check the condition of pre cleaner dust fan.
- Check the condition of air cleaner restrictions.
- Check the oil bath filter and level of oil bath.
- Check the vibration and tightness of bolts.

### **Batteries**

- Check the level of electrolyte and top up if necessary
- Check the SPG of electrolyte and measure the battery voltage.
- Check the tightness of connections for any overheating and abnormality.
- Check the condition of body.
- Check charging current and charging system, floating current should be 1 Amp.
- Check condition of intercell connections for any overheating and abnormality.

### **Switch Gear**

- Check automatic starting switch for its proper functioning.
- Check any abnormality if visualized.
- Check phase indications and working of panel meters.

### **Alternator**

- Check any abnormality, if visualized.
- Check the air-in and out restrictions.

## **MONTHLY SCHEDULE**

In addition to Daily & Weekly schedule, carry out the following checking;

### **Engine**

- Check the condition of aneroid oil.
- Drain the fuel, sediments and water and clean the tank.
- Clean the filters.
- Check the condition of magnesium plate assembly.
- Check the radiator air restrictions for any leaks
- Check the condition of crankcase breather.
- Check the air filters of air cleaner elements.
- Check the condition of breather and change if reqd.
- Check the condition of exhaust manifolds.
- Check the condition of turbo charger cap screw

## **Batteries**

Weekly schedule

## **Switch Gear**

- Check visually all the panel instruments.
- Check the tightness of connections and tighten if required.

## **Alternator**

- Check the condition of electrical connections and tighten if required
- Check visually all the windings for any overheating.

## **SIX MONTHLY SCHEDULE**

In addition to Daily, weekly & monthly schedules carry out the following checking;

### **Engine**

- Change engine oil.
- Change lubricating oil for filter element and check for metal particles and oxidation
- Clean oil bath air cleaner tray screen with the help of clean solvent.
- Clean main fuel tank breather by using clean solvent.
- Check the coolant pH value, if it is below (8.5 to 10.5) normal range then chromate concentration should be 3500 ppm
- Check the magnesium plate for pitting or being eaten. In case of 50% area is lost, change it.
- Change water filter element.
- Change fuel filter element washer and 'O' rings on mounting bolt and clean shell fuel filter.
- Check and adjust the belts. In case of change of new belts, which will stretch within one hour of use and must be readjusted keeping tension of belts within permissible limits.
- Check all air cleaner connections for cracks, chafing etc, and tighten all air intake connections.
- Check the throttle linkage.
- Remove and clean air compressor delivery hose.
- Check crank case breather element.

### **BATTERY**

Same as monthly schedule.

### **SWITCH GEAR**

Check condition of switches/ circuit breakers for it's proper operation.  
Check the condition of contacts and tighten if required. In case of burn out, replace the contacts.

## **ALTERNATOR**

Visually examine the terminal box, junction box and insulator etc, and clean them by using dry and clean cloth

Check condition of cooling fan.

## **YEARLY SCHEDULE**

The following checks should be carried out In addition to routine checks;

### **Engine**

- Check the water pump and drive.
- Check mounting bolt and bearing end play.
- Clean air cleaner after removing complete assembly.
- Clean and tighten all electrical connections.
- Clean entire engine with the help of high pressure air and soap water mixture. Take care for protecting electrical system during cleaning.
- Tighten all mounting bolts and nuts and avoid overtightening which may result in distortion or damage.
- Clean radiator by blowing air through the radiator core in opposite direction to the normal flow of the air.
- Check air compressor including shaft end clearances.
- Adjust injector and valves, it must be carried out with engine hot.
- Check condition of thermostat, change if required.

## **BATTERY, SWITCH GEAR, ALTERNATOR**

Same as six monthly schedules

## **TWO YEARLY SCHEDULE**

The following checks should be carried out In addition to routine checks;

### **ENGINE**

Check the exhaust and inlet manifold nuts and cap screws.

Check the crank shaft float.

Check injector inlet screens

Clean and calibrate injector and fuel pump.

Replace fuel pump filter screen and magnet.

Steam clean engine or as per yearly schedule.

Check vibration dampers and replace if necessary.

### **BATTERY**

Same as six monthly schedules

### **SWITCH GEAR**

Check condition of insulation of all the wires.

Check the wires and cables properly.

## **ALTERNATOR**

Check the insulation resistance of the windings.

## **FOUR YEARLY SCHEDULE**

When the engine operating conditions deteriorate in performance, it can be ascertained by the following symptoms.

Heavy smoke.  
Loss of power.  
High oil and water temperature.  
Loss of lubricant, oil pressure  
Unusual noise and vibrations.

The above checks are inspection of wear or assembly deterioration of parts and assemblies, which should be restored to only after trouble shooting in addition to the routine maintenance checks which may eliminate the engine performance problems and being the engine back to its normal operations.

It is essential that the above checks be strictly followed in order to prevent dismantling of the engine whose performance can be simply corrected by trouble shooting and routine maintenance checks

## **ELECTRICAL**

In addition to all the routine maintenance schedules, the following checks should be carried out

Check the capacity of battery as per IS and if the capacity is less than 80% replace the battery.

## **SWITCH GEAR**

Check condition of insulation of all the wires.  
Check the wires and cables properly by insulation resistance values..

## **ALTERNATOR**

Check the insulation resistance of the windings.

### 13. What is UPS? Explain with neat sketch?

Ideally, the voltage supply by the utility system should be perfect sine wave without any harmonics, at its nominal frequency of 50Hz and at its nominal magnitude. In practice however, voltage can significantly depart from the ideal condition due to power line disturbances like over voltage, under voltage, outage, voltage spikes, harmonics and electromagnetic interference. Uninterruptible Power Supply System is used for supplying critical loads like computer/data processing machines, hospitals, control and instrumentation, communication equipment and critical processes in industries. This provides protection against power outages as well as voltage regulation. They are also excellent in terms of suppressing incoming line transients and harmonic disturbances.

An uninterruptible power system (UPS) is insurance in a hardware form to protect against data loss, equipment downtime and revenue loss.

These are two types of UPS (i) ON load UPS (ii) OFF load UPS and the block diagram of typical ON load & OFF load UPS are shown below.

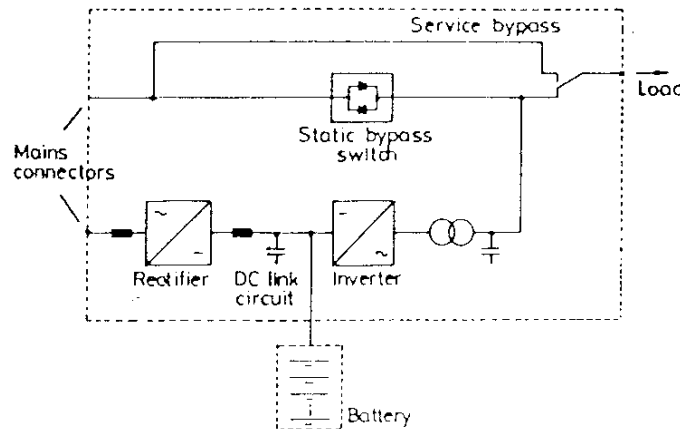

Fig 1 On line UPS Block diagram

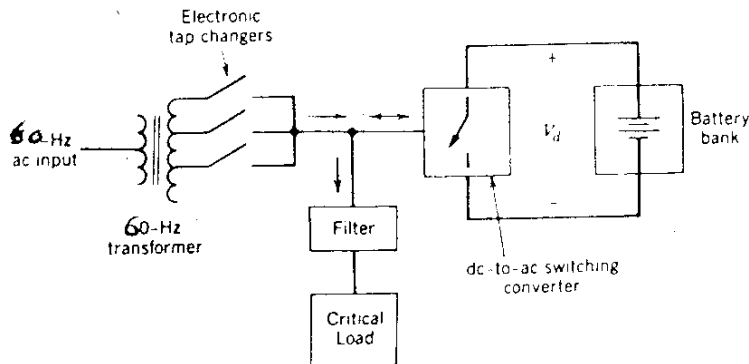

Fig 2 Off-line UPS arrangement



**ON load UPS:**

The input rectifier feeds to battery as well as the load all the time. Battery remains in floating condition and takes over as soon as the main goes off. This gives conditioned output of fixed frequency, fixed voltage irrespective of line condition.

**OFF load UPS:**

In OFF load UPS system, battery bank is usually not connected to the load. It comes into circuit only when the mains are OFF. As shown in the block diagram, in normal mode the switching converter operates as rectifier, charging the battery bank. In addition, it can draw, inductive or capacitive currents from the mains, these providing a fine regulation of the voltage supplied to the load. In case of main power outage, the power is isolated and the switch, converter operates or an inverter, supply power to the load for the battery bank. The response time of the “OFF load UPS” is slower compared to “ON load UPS”.

**14. What are the differences between OH & UG cable?**

	<b>Description</b>	<b>Overhead line</b>	<b>Underground(UG cable)</b>
1	General appearance	Not good	Good appearance
2	Installation cost	normal	More
3	Maintenance cost	more	less
4	Chances of fault	more	Less
5	Fault finding	Easy	Not so easy
6	Periodic maintenance	required	Not required
7	safety	less	More
8	Type of conductor	Aluminium	3 core(or) 3 ½ core LT UG cable
9	Calculation of sag	Essential	Nil
10	Application	No limitation	Limited to 132Kv only

## 15. What do you mean by radial & ring main type of distribution?

### Ring Main system (looped system)

In Ring main system all the loads are connected to form a closed ring around the substation. The ring main has the advantage of duplicate mains with less cost. Ring mains may be used for high tension as well as low-tension circuits.

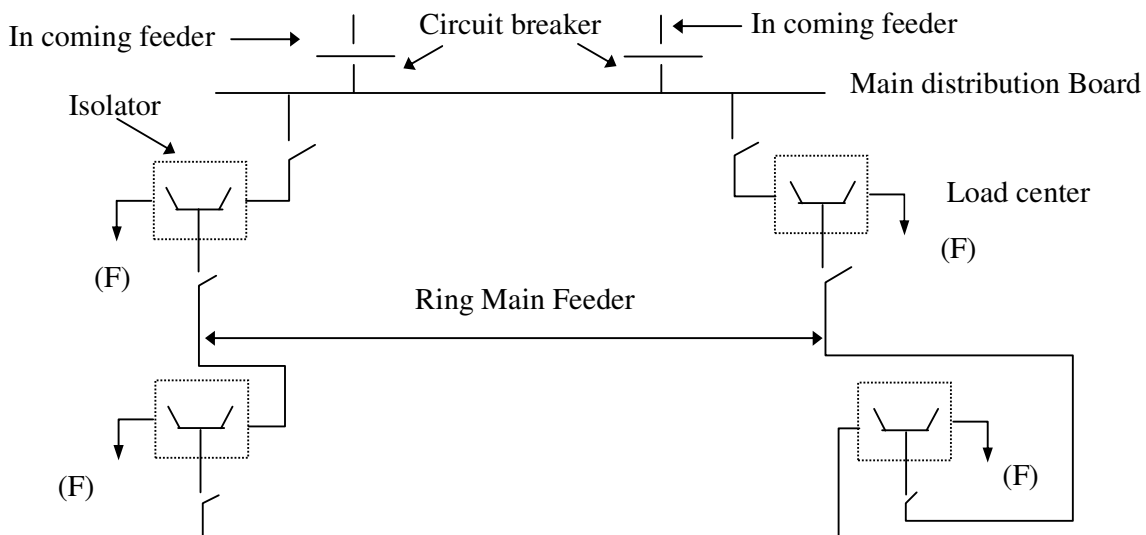

From the figure, it can be seen that each load center has two sources. In this case the reliability of the system is better, compared to radial system. In the case of fault at any point in the system, supply can be maintained to all the load centers by isolating the faulty distribution line.

### Radial system.

The most common method employed in the distribution of power is the radial feeder system. In this system each load centre is fed by a separate feeder from substation and each feeder is independent of the others and has separate controls at the substation. The drawback of this arrangement is that there is no possibility of an alternative feed in the event of any failure of a particular feeder.

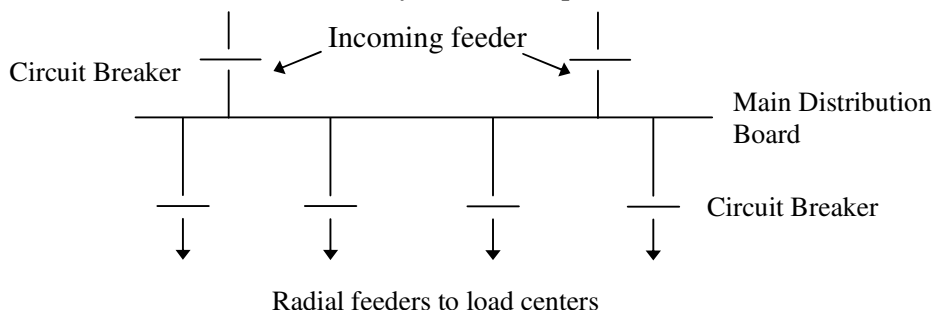

## 16. Write down the details of power line crossing?

### Definition:

- Power line crossing means, Electrical overhead line or UG cable placed across the Railway track for transmission or distribution of electrical energy.
- Crossing rules not applicable to feeders/conductors/wires of the Railway traction system.
- The owner of the crossing, before execution of the crossing should obtain the approval in writing of the Railway for the proposed location, detailed design and method of execution etc.
- The owner should advise in writing 15 days prior to the commencement of the work
- Before bringing in to use a certificate of compliance should be submitted to Railways.
- Any disturbance to rail should be under the direct supervision of the Railway official and the cost of such works should be borne by the owner of the crossings.

### Methods of crossings:

- Up to and including 11 KV crossing should be by means of UG cables.
- In special cases EI may permit overhead crossing up to 11 KV in non-electrified section with a minimum vertical clearance 10.95 metre above rail level subject to the condition that the crossing will be modified by the owner at his cost whenever Railway demands.
- Crossing should not in any way interfere with any communication line
- No work of maintenance of the crossing without the consent from the Railways
- Maintenance under the supervision of railways
- Fitness should be inspected once in a year. Defects should be rectified promptly
- All defects, failures line snapping of conductors, breaking of insulators etc which are likely to affect the safe movement of Rail traffic should be reported forthwith by the owner of the crossing to the SM on-duty on both sides of the crossing as well as to CEE, DRM, DRM/E, EI & Director (transmission)/Central Electricity Board.
- A detailed report with in 48 hours of the first report.

## TECHNICAL POINTS TO BE CHECKED FOR THE POWER LINE CROSSINGS

### Overhead line crossing

#### Angle of crossing:

- Normally be at right angles to the Railway track.
- Deviation of upto 30 deg. is permitted.
- Deviation more than 30 deg. Requires the approval of the Electrical Inspector.

**Structures:**

- Steel poles/masts
- Fabricated steel structures (Galvanized)
- Reinforced or pre-stressed concrete poles
- should be self supporting or guyed type
- Minimum distance of the structure from the centre of the nearest track should be  
= (Ht. of the structure in meters above the ground level + 6 meters).
- Relaxation to the minimum distance of the structures: EI can relax the condition under special circumstances to the above stipulations subjected to the conditions he deems fit.

**Span:**

- Not more than 300 meters or to 80% of the normal span for which the structures are designed, which ever is less.

**Wind pressure and Temperature:**

- Maximum wind pressure for the structure and maximum temperature for the conductor shall be as prescribed in the later versions of IS 801 part-1

**Provision of snow loading:**

- Based on the local conditions and with the approval of Railway.

**Factor of Safety:**

- Metal supports: 1.5
- Mechanically processed concrete supports: 2
- Hand mould concrete supports: 2.5
- Wooden supports:3
- Stay wires, Guards: 2.5
- Conductors: 2

**Location and clearances:**

- Preferably located at the middle of the OHE span
- The distance between the crossing conductor and nearest traction mast or structure under most adverse condition should not be less than 6 meters.
- NO crossing over the BT, TS, TSS in an electrified area.

**Vertical clearances:**

- The minimum ht. above rail level of the lowest portion of any conductor of the crossing including guard wire under condition of max sag shall be as follows:  
(Dimensions in Meters)

Sl.No	Voltage	BG/MG/NG
1	11 KV	Cable
2	11-66	14.10
3	66-132	14.6
4	132-220	15.4
5	220-400	17.9
6	400-500	19.3
7	500-800	23.4

- Clearances between crossing conductors and any Rly. Structure: [IE RULE 80]
- Where a high or extra-high voltage overhead line passes above or adjacent to any building a vertical clearance above the highest part of the building immediately under such line, of not less than-
  - for high voltage lines upto and including 33,000 volts 3.7 metres
  - for extra-high voltage lines 3.7 metres plus 0.30 metre for every additional 33,000 volts or part thereof.
  - The horizontal clearance between the nearest conductor and any part of such building shall, on the basis of maximum deflection due to wind pressure, be not less than-
    - (a) for high voltage lines upto and including 11,000 volts 1.2 metres
    - (b) for high voltage lines above 11,000 volts and up to and including 33,000 volts 2.0 metres
    - (c) for extra-high voltage lines 2.0 metres plus 0.3 metre for every additional 33,000 volts for part thereof.

**Vertical clearances between crossing conductors:  
{ IE RULE 87 }**

- Minimum vertical clearance to be maintained between any of the power line crossing at the same voltage or at different voltage shall be as specified in IE rule 87.
- Where an overhead line crosses or is in proximity to another over head line, guarding arrangements shall be provided so to guard against the possibility of their coming into contact with each other Except when the voltage of higher line is 33 KV and above
- When such guarding is provided the clearance from the guard wires to the lower power line should not be less than 2 metres and to the upper power line not less than 1.5 metres.

**OVERHEAD CROSSINGS**

**Insulators:**

- Double set of strain insulator strings shall be used in crossing span
- Each string of such strain insulator shall have one insulator more than the number used in a normal span of the OH line
- Factor of safety of such string insulator shall not be less than 2.

**Guarding:**

- Upto and including 33 KV shall be provided with guarding under the power line.
- NO guarding is necessary of voltages above 33 KV if the transmission line is protected by Circuit breakers with total tripping time of 0.2 seconds for voltages upto 220 KV and
- second for voltages of 220 KV and above from the time of occurrence of the fault to its clearance.
- The minimum height above the rail level to the lowest level of any guard level under conditions of maximum sag shall not be less than the prescribed values:  
Ex: 66 KV =>2.44 ; 110 => 2.75
- Minimum ht. between any guard wire and a live crossing conductor under the most adverse weather conditions should not be less than 1.5 metres.

- Anti climbing devices and warning notices:
- Where the voltage exceeds 650 volts the supporting structure of the crossing should be provided with anti climbing devices.
- Caution boards shall also be erected on all such structures in tri-languages
- Protection from Road vehicles:
- Supporting structures, including guys adjacent to road ways should be so located that the danger of their being struck by moving road vehicle is avoided.

**Earthing:**

- Each structure on either side of the crossing span supporting the crossing should be earthed effectively by two separate and distinct earth connections
- One separate earth electrode should be provided for each connection
- All guard and stay wires should be properly earthed to the structures
- Earth resistance should be less than or equal to TEN ohms.
- Earth should be inspected and tested annually on a hot dry day and the results submitted to Railways.

**Under ground Cable crossing:**

**Method of Laying:**

- Cables should be laid through Cast Iron pipes or spun concrete pipes of suitable strength and dia.
- Pipe should be laid not less than one metre depth below the formation level
- It should be possible to withdraw the cables for repairs/replacement
- To facilitate the drainage water pipes should be laid in a gradient
- Pipes should be laid up to the Railway boundary on both ends or up to the prescribed points as specified by the Railways
- Cable laying should be as per the code of practice IS 1255

**Earthing:**

- Armoring shall be earthed on both ends by independent earths at two sealing ends.
- No further earthing within 500 meters of the electrified track.
- The scheme of the earthing shall be got approved by Railway.
- Under ground Cable crossing:
- Structure to which the cables are connected should comply with the regulations applicable OH line crossings.

**Markings:**

- Two cast iron markers
- Marker should contain
- Voltage
- No. of cables
- Danger
- Depth of the cable below track level & ground level
- Off set